



2065843808

Order no. P206 0466 13 Part no. 206 584 38 08  
Edition B-2024



C-Class

Mercedes-AMG Supplement

Mercedes-Benz



## Publication details

### Internet

Further information about Mercedes-Benz vehicles and about Mercedes-Benz AG can be found on the following websites:

<https://www.mbusa.com> (USA only)

<https://www.mercedes-benz.ca> (Canada only)

### Documentation team

©Mercedes-Benz AG: Not to be reprinted, translated or otherwise reproduced, in whole or in part, without written permission from Mercedes-Benz AG.

### Vehicle manufacturer

Mercedes-Benz AG

Mercedesstraße 120

70372 Stuttgart

Germany

As at 25.04.23

### Thank you for purchasing a Mercedes-AMG

Before your first drive, please read this Operator's Manual carefully and familiarize yourself with your vehicle. For your own safety and a longer service life of the vehicle, follow the instructions and warning notices in this Operator's Manual. Disregarding them may lead to damage to the vehicle or injury to people.

Damage to the vehicle resulting from the disregard of the instructions is not covered by the Mercedes-Benz Limited warranty.

The standard equipment and product description of your vehicle may vary and depends on the following factors:

- Model
- Order
- National version
- Availability

Your vehicle may therefore differ from that shown in the descriptions and illustrations in individual cases.

Mercedes-AMG reserves the right to introduce changes in the following areas:

- Design
- Equipment
- Technical features

The following documents are integral parts of the vehicle:

- Digital operator's manual
- Printed Operator's Manual
- Maintenance Booklet
- Supplementary manuals relating to specific equipment
- Supplementary documents

Keep these documents in the vehicle at all times. Ensure that all documents are in the vehicle or passed on in the event of sale or rental.

Mercedes-Benz USA, LLC

Mercedes-Benz Canada, Inc.

A Mercedes-Benz Group AG Company

2065843808



<b>Symbols</b> .....	3	<b>Driving and parking</b> .....	12	<b>Breakdown assistance</b> .....	47
		Driving .....	12	Removing the warning triangle .....	47
		DYNAMIC SELECT .....	16	Notes on starting assistance .....	47
<b>At a glance</b> .....	4	Automatic transmission .....	21	Permissible towing methods (Mercedes-AMG E Performance) .....	47
Cockpit .....	4	Driving and driving safety systems .....	22		
<b>General notes</b> .....	6	<b>Driver's display</b> .....	30	<b>Wheels and tires</b> .....	48
Operator's Manual .....	6	Notes on the driver display .....	30	Changing a wheel .....	48
Protection of the environment .....	6	Operating the driver display .....	31		
Operating safety .....	6	Driver display menus .....	32	<b>Technical data</b> .....	49
Qualified specialist workshop .....	8	Function of the power meter .....	37	Operating fluids .....	49
Notes for persons with electronic medical aids .....	8	Overview of status indicators on the driver display (Mercedes-AMG vehicles) .....	38	Vehicle data .....	51
<b>Occupant safety</b> .....	9	<b>Notes on radio reception</b> .....	40	<b>Display messages and warning/indicator lamps</b> .....	54
Restraint system .....	9	Operating Touch Control (MBUX multimedia system) .....	40	Display messages .....	54
Seat belts .....	9	AMG TRACK PACE .....	40	Warning and indicator lamps .....	56
<b>Climate control</b> .....	10	<b>Maintenance and care</b> .....	46	<b>Index</b> .....	59
Pre-entry climate control when the vehicle is unlocked .....	10	Notes on the care of tailpipes .....	46		

In this Operator's Manual, you will find the following symbols:

**⚠ WARNING** Danger due to failure to observe the warning notices

Warning notices draw your attention to hazards that may endanger your health or life, or the health or life of others.

▶ Observe the warning notices.

**🌿 ENVIRONMENTAL NOTE** Environmental damage due to failure to observe environmental notes

Environmental notes include information on environmentally responsible behavior or environmentally responsible disposal.

▶ Observe environmental notes.

**! NOTE** Damage to property due to failure to observe notes on material damage

Notes on material damage inform you of risks which may lead to your vehicle being damaged.

▶ Observe notes on material damage.

**ⓘ** These symbols indicate useful instructions or further information that could be helpful to you.

▶ Instruction

(→ page) Further information on a topic

Display Display in the central display

↪ Highest menu level, which is to be selected in the multimedia system

▶▶ Relevant submenus, which are to be selected in the multimedia system

\* Indicates a cause

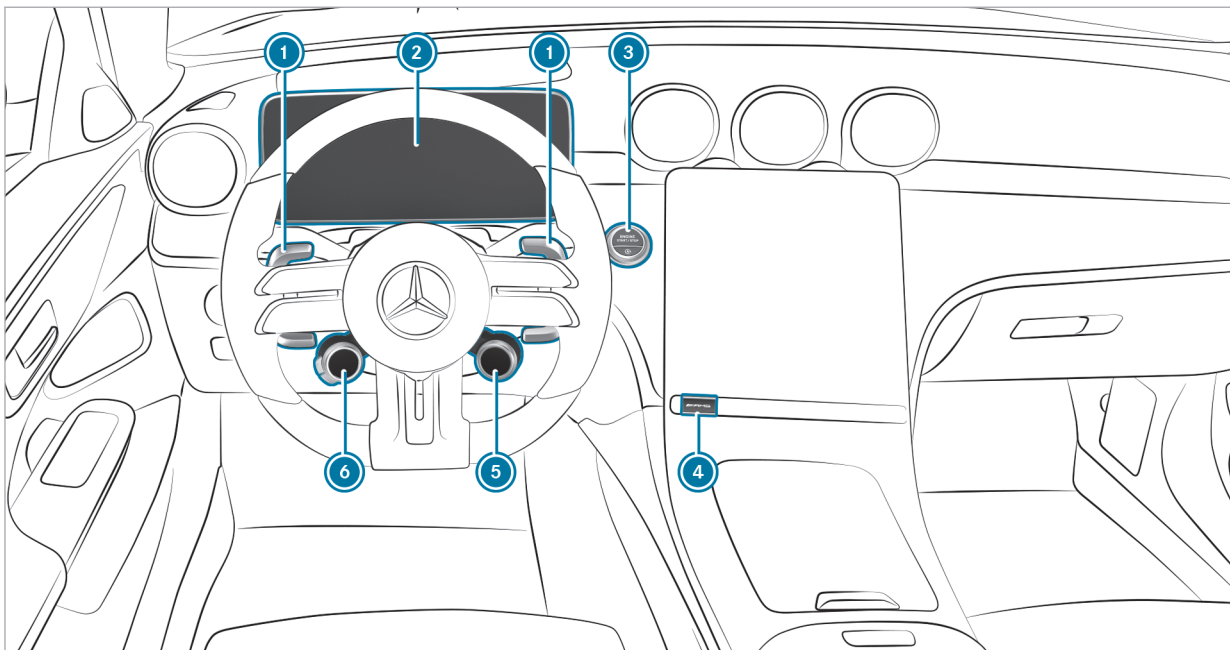

Left-hand drive vehicles

---

① Steering wheel paddle shifters	→	21	⑤ Selects the drive program	→	18
② Driver display	→	31	⑥ AMG steering wheel buttons	→	13
③  Start/stop button					
④ Sets AMG DYNAMIC SELECT in the MBUX multimedia system	→	20			

---

### Operator's Manual

These Operating Instructions provide information on all the important functions of your AMG vehicle that are either not described or differ from the descriptions in the Operator's Manual. This information supplements or replaces the corresponding sections in the vehicle Operator's Manual. Under no circumstances do the Operating Instructions replace the printed vehicle Operator's Manual and the Digital Operator's Manual in the vehicle.

These Operating Instructions provide information on all the important functions of your AMG hybrid vehicle that are either not described or differ from the descriptions in the Operator's Manual. This information supplements or replaces the corresponding sections in the vehicle Operator's Manual. Under no circumstances do the Operating Instructions replace the printed vehicle Operator's Manual and the Digital Operator's Manual in the vehicle.

This Supplement and the Digital Operator's Manual in the vehicle describe the following models, standard and special equipment of your vehicle:

- Models, standard and special equipment available at the time of going to press with these Operating Instructions.
- The models and the standard and special equipment only available in certain countries.
- The models and the standard and special equipment, which will only be available at a later date.

Note that your vehicle may not be installed with all features described. This is also the case for systems relevant to safety. Therefore, the equipment on your vehicle may differ from that in the descriptions and illustrations.

The original purchase agreement for your vehicle contains a list of the equipment in your vehicle at the time of delivery.

Should you have any questions concerning equipment and operation, please consult an authorized Mercedes-Benz Center.

The Operator's Manual, Operating Instructions, further supplementary documents and Maintenance Booklet are important documents and should be kept in the vehicle.

### Protection of the environment



**ENVIRONMENTAL NOTE** Environmental pollution caused by irresponsible disposal of the high-voltage battery

A high-voltage battery contains materials which are harmful to the environment.



Dispose of defective high-voltage batteries at a qualified specialist workshop.

### Operating safety

Hybrid vehicles have a combustion engine and at least one electric motor. The voltage supply for operating the vehicle electrically is provided by the vehicle's high-voltage electrical system.



**⚠ DANGER** Risk of death and fire due to modified and/or damaged components of the high-voltage on-board electrical system

The vehicle's high-voltage on-board electrical system is under high voltage. If you modify component parts in the vehicle's high-voltage on-board electrical system or touch damaged component parts, you may be electrocuted. In addition, modified and/or damaged components may cause a fire.

In the event of an accident or impact to the underbody, components of the high-voltage electrical system may be damaged although the damage is not visible.

- ▶ Never make any modifications to the high-voltage on-board electrical system.
- ▶ Do not switch on or use the vehicle if its high-voltage on-board electrical system components have been modified or damaged.

- ▶ Never touch damaged components of the high-voltage on-board electrical system.
- ▶ After an accident, do not touch any components of the high-voltage on-board electrical system.
- ▶ After an accident, have the vehicle transported away.
- ▶ Have the components of the high-voltage on-board electrical system checked at a qualified specialist workshop and replaced if necessary.

The components of the vehicle's high-voltage electrical system are marked with yellow warning stickers. The cables of the vehicle's high-voltage electrical system are orange in color.

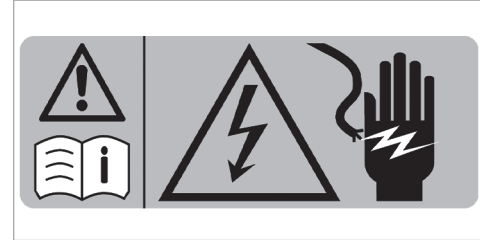

Example

High-voltage components that can become very hot are marked with an additional warning sticker:

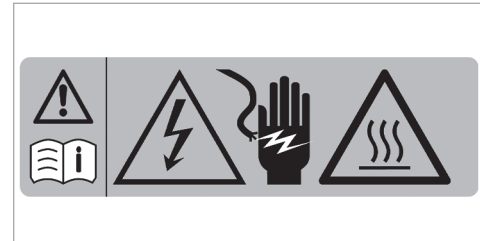

Vehicles with hybrid systems generate significantly less noise when stationary and when being driven than vehicles with combustion engines.

When you are driving in electric mode, the vehicle may not be heard by other road users due to the significantly lower noise generated when they are being driven and when stationary.

It is for this reason that the vehicle is equipped with a sound generator, which serves as an acoustic vehicle alerting system (AVAS). This safety system is prescribed by law.

The outside sound produced by the sound generator (AVAS) can be heard in the passenger compartment at low speeds and does not represent a malfunction.

### Qualified specialist workshop

Always have the following work carried out on your vehicle at a qualified specialist workshop:

- Safety-relevant works
- Service and maintenance work
- Repair work

- Modifications as well as installations and conversions
- Work on electronic components
- Work on the hybrid system

### Notes for persons with electronic medical aids



When charging the high-voltage battery, keep a distance of at least an arm's length between the medical aid and the following components:

- The power supply equipment  
This includes charging stations in the form of a wallbox or a public charging point, for example.
- Vehicle components carrying live voltage  
This includes the charging cable and the charging control box, for example.

## Restraint system

### Malfunctioning restraint system

A malfunction has occurred in the restraint system if:

- The  restraint system warning lamp does not light up when the vehicle is switched on
- The  restraint system warning lamp lights up continuously or repeatedly during a journey

If the restraint system is malfunctioning, in the event of an accident the high-voltage on-board electrical system may not be deactivated as intended.

**⚠ DANGER** Risk of death due to the restraint system malfunctioning

Components in the restraint system may be activated unintentionally or not deploy as intended in an accident. In the event of an accident, the high-voltage on-board electrical system may not be deactivated as intended.

You may receive an electric shock if you touch the damaged components of the high-voltage on-board electrical system.

- ▶ Have the restraint system checked and repaired immediately at a qualified specialist workshop.
- ▶ After an accident, switch off the vehicle immediately.

## Seat belts

### Limitations of the protection provided by the seat belt

The AMG sports seat and the AMG Performance seat are designed for the standard three-point seat belt. If you install a different multipoint seat belt, for example a four-point seat belt, the restraint system cannot provide the intended level of protection.

Depending on the type of vehicle, there may be openings in the seat backrest. These openings have no function.

**⚠ WARNING** Risk of injury or fatal injury due to modified seat belt systems

If you feed seat belts through the opening in the seat backrest, the seat backrest may be damaged or may even break in the event of an accident.

- ▶ Only use the standard three-point seat belt.
- ▶ Never modify the seat belt system.

### Pre-entry climate control when the vehicle is unlocked

#### Function of pre-entry climate control when the vehicle is unlocked

The seats can be briefly preheated or precooled before you get into the vehicle.

- ① This function is available only for plug-in hybrid vehicles.

Depending on the vehicle's equipment, the following functions will be activated as needed during precooling:

- Automatic climate control
- Blower
- Seat ventilation

Depending on the vehicle's equipment, the following functions will be activated as needed during preheating:

- Automatic climate control
- Blower
- Seat heating

- Steering wheel heater
- Panel heating
- Mirror heater
- Rear window defroster

#### Setting pre-entry climate control when the vehicle is unlocked in the multimedia system

Multimedia system:

↳ Climate Menu ▶▶ Pre-entry Climate Ctrl.

- ① This function is available only for plug-in hybrid vehicles.
- ▶ Activate or deactivate the function.

#### Selecting seats

- ▶ Select **Driver**, **Passenger**, **Rear Left** or **Rear Right**.  
The seat-specific functions of pre-entry climate control (e.g. seat heating) will be performed for the selected seats.

When pre-entry climate control is enabled, an LED on the climate bar on the central display will light

up blue for a cooled vehicle and red for a heated vehicle.

#### Activating/deactivating pre-entry climate control when the vehicle is unlocked

##### Requirements

- The high-voltage battery is charged sufficiently.
- The function has been activated via the multimedia system.

- ▶ **To switch on:** unlock the vehicle.  
The climate control functions are activated for up to five minutes for pre-heating and pre-cooling.

Pre-entry climate control when the vehicle is unlocked cannot be activated more than twice when the vehicle is switched off.

- ▶ **To switch off:** press  on the climate bar on the central display (see Operator's Manual for the vehicle).

Depending on the vehicle equipment, the following functions will remain active once the vehicle has been started:

- Seat heating
- Seat ventilation
- Panel heating

## Driving

### Notes on plug-in hybrids

Observe the notes on plug-in hybrids in the Operator's Manual; otherwise, you may fail to recognize potential dangers.

#### Notes on plug-in hybrid operation

- The **Mercedes-AMG C 63 S E PERFORMANCE** model can be accelerated in electric mode up to a speed of approximately 77 mph (125 km/h).
- In the **C** and **B** drive programs, the hybrid system will select the appropriate drive type depending on the driving situation (→ page 16).
- In the **EL** drive program, the vehicle will drive in electric-only mode, and in the **E**, **S**, **S+** and **S+** drive programs, the combustion engine will be on at all times.

#### Charge the high-voltage battery

Refer to the instructions for charging the high-voltage battery in the Operator's Manual to avoid damage and accelerated aging.

- If you use the high-voltage battery exclusively at low states of charge, fully charge the high-voltage battery every six months.

Depending on the equipment and national version, your vehicle will be equipped with a vehicle socket type 1 or type 2 for single-phase AC charging.

Charging options for the high-voltage battery (mode 2 or 3):

- during travel by means of recuperation
- stationary AC charging:
  - at a mains socket (mode 2)
  - at a wallbox or charging station (mode 3)

### Notes on engine output and engine torque (Mercedes-AMG vehicles)

- The actual (maximum) values that can be achieved for engine output and engine torque may deviate from the certified values within the country-specific provisions for permissible tolerances (basis: UN-ECE No. 85 or country-specific provisions).

Influencing variables that can influence this are, for example:

- Location above sea level
- Fuel grade
- Outside temperature
- Operating temperature of the engine

Until the engine has reached its operating temperature, the  engine operating temperature warning lamp is lit.

Engine output and engine torque have been reduced. Take this into account in your driving style.

When the engine operating temperature warning lamp  goes out, full engine output and full engine torque are available.

## Function of the AMG steering wheel buttons

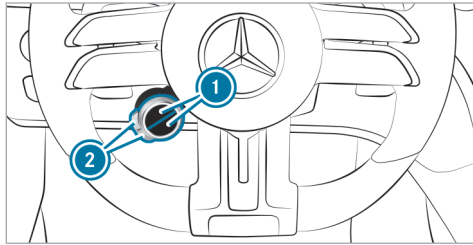









The AMG steering wheel buttons are an additional control element with two buttons on the steering wheel.

You can assign two vehicle functions of your choice to the control element. You can change between the available functions for corresponding button ① by pressing the upper or lower part of display buttons ② repeatedly. Display buttons ① show each function selected.

The following functions are available depending on the equipment:

 ESP® (→ page 22)

-  AMG RIDE CONTROL
-  Manual gearshifting (→ page 21)
-  ECO start/stop function (→ page 14)
-  AMG Real Performance Sound (→ page 15)
-  **Plug-in hybrid:** AMG Real Performance Sound (→ page 15)
-  Camera views (see the vehicle's Operator's Manual)
-  AMG DYNAMICS (→ page 16)
-  **Plug-in hybrid:** Boost strategy (→ page 28)

In addition, all the functions you have saved as favorites in the multimedia system will be available for selection. Information on favorites in the multimedia system and their configuration (see the vehicle's Operator's Manual).

- ① Individual functions may be faded out. How functions are displayed and the order in which they are displayed can be set in the multimedia system (→ page 13).

If you have assigned a specific function to one of display buttons ①, you will be able to operate that function with corresponding button ②.

The assignment of display buttons ① will remain stored even after the vehicle has been started again. The operating status of the respective function will, however, be reset to the basic setting.

## Setting the AMG steering wheel buttons

Multimedia system:

-  **▶ Settings ▶ System**
- ▶▶ Control Elements**
- ▶▶ AMG Steer. Wheel Buttons**

- ① The **SETTINGS SELECT** menu can also be called up using the AMG button in the center console or by pressing and holding the respective display button.

The left display buttons on the steering wheel can be set in the **SETTINGS SELECT** menu.

- ▶ Select the upper or lower display button in the central display and switch to editing mode by pressing and holding it.

- ▶ Press **+** and select the desired function from the list.  
The selected function is assigned to the corresponding display button and can now be called up directly by simply pressing it.

#### Deleting button assignment

- ▶ Select the upper or lower display button and switch to editing mode by pressing and holding it.
- ▶ Press **X** to delete the selected display button assignment.

#### Turning the ECO start/stop function on or off with the steering wheel button (Mercedes-AMG vehicles)

Observe the notes on the ECO start/stop function in the vehicle Operator's Manual.

- i** **Plug-in hybrid:** The ECO start/stop function is not available.
- i** You can also turn the ECO start/stop function off or on via the multimedia system.

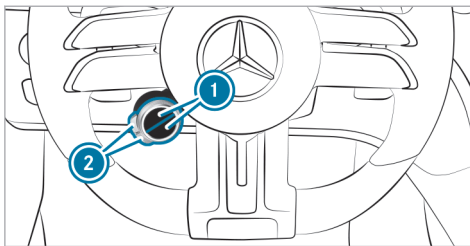

- ▶ Press the upper or lower **1** display button repeatedly, until it displays the **A** symbol.

**i** If the display button does not show the symbol, then it is hidden. How functions are displayed and the order in which they are displayed can be set in the multimedia system (→ page 13).

- ▶ Press corresponding button **2**.

The symbol shows the current status of the ECO start/stop function:

- **A<sup>OFF</sup>** (red): off
- **A** (green): active
- **A** (yellow): inactive

#### Recuperative brake system (plug-in hybrid)

#### Manually setting recuperative deceleration (Mercedes-AMG vehicles)

##### Requirements

- Drive program **EL**, **B**, **C**, **S** or **S** is selected.
- ESP<sup>®</sup> is activated – ESP<sup>®</sup> ON.
- Active Distance Assist DISTRONIC is not activated.

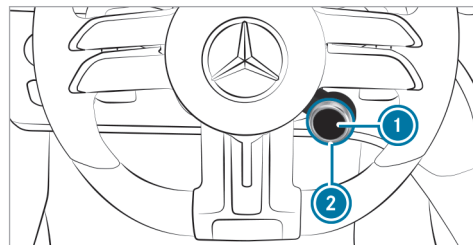

The higher the recuperation, the more sharply the vehicle is braked when coasting and the more



electrical energy is fed into the high-voltage battery.

**i** When the vehicle is started again or transmission position **D** is engaged again, standard recuperation is automatically set.

**▶** Press display button **1**.

The display button will show the  symbol with a three-part segment display for setting the recuperation.





**i** If the display is grayed out, the requirements are not met and setting is not possible. If the charging potential of the high-voltage battery is reduced, e.g. due to a high state of charge or a high-voltage battery that is not yet at operating temperature, it may not currently be possible to set a recuperation level. The **Desired Recuperation Level Currently Unavailable** message will then be shown on the instrument display.

When the  symbol is shown with a red ! on the display button, the regenerative brake system is malfunctioning. Observe the information on warning lamps and display messages that are shown on the driver's display.

**▶ To increase recuperation:** turn rotary switch **2** clockwise in the **+** direction.

**▶ To reduce recuperation:** turn rotary switch **2** counter-clockwise in the **-** direction.

The following recuperation levels are available and are shown on display button **1**:

-  and no segments light up: no recuperation, the vehicle rolls freely
-  and one segment lights up: standard recuperation
-  and two segments light up: increased recuperation, heavy deceleration in overrun mode, e.g. for driving on downhill gradients
-  and three segments light up: maximum recuperation, maximum deceleration in overrun mode

**i** In drive programs **EL**, **C** and **B**, the intensity of the recuperation on downhill gradients will be adjusted as needed: the steeper the incline, the higher the recuperation. Depending on the situation, it may nevertheless be necessary to additionally depress the brake pedal.

If the charging potential of the high-voltage battery has to be reduced due to an increasing high state of charge, e.g. when you are driving downhill for a long time, the recuperation level will automatically be reduced. The **Recuperative Deceleration Temporarily Reduced** message will then be shown on the instrument display.

## AMG Real Performance Sound

### Selecting a sound characteristic with the steering-wheel button

**i** You can select a comfortable (Balanced) or a sporty (Powerful) sound characteristic using the steering-wheel button or the multimedia system (→ page 20).

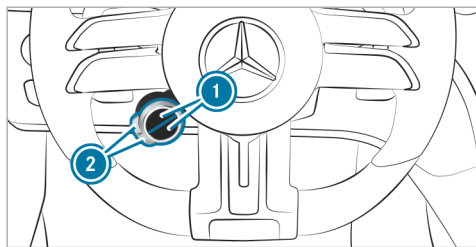

▶ Press upper or lower display button ① repeatedly until it displays the  symbol.

**Plug-in hybrid:** display button ① will show the  symbol for the sound characteristic.

① If the display button does not show the symbol, then it is hidden. How functions are displayed and the order in which they are displayed can be set in the multimedia system (→ page 13).

▶ Press corresponding button ②.

The color of the button symbol indicates the currently selected sound characteristic:

- **Blue:** Balanced – comfortable

- **Red:** Powerful – sporty

① **Plug-in hybrid:** With the sporty sound characteristic (Powerful), the vehicle will produce speed-dependent driving noise up to approximately 62 mph (100 km/h).

#### Information on the AMG ceramic high-performance composite brake system

The brake system is designed for heavy loads. This may lead to noise when braking. This effect can also occur after washing the vehicle.

The noise depends on the following factors:

- speed
  - brake force
  - environmental conditions, e.g. temperature and air humidity
- ① Have the brake system checked at a qualified specialist workshop after it has been subjected to extreme loads.



#### DYNAMIC SELECT

##### Function of DYNAMIC SELECT (Mercedes-AMG vehicles)

DYNAMIC SELECT allows a drive program to be selected quickly according to the current driving conditions or the desired vehicle characteristics.

① Depending on the engine and equipment, the vehicle will have different drive programs.

You can select the following drive programs:

-  **Slippery**
  - optimize pulling away and driving characteristics in wintry and slippery road conditions
  - Drive with combustion engine only (plug-in hybrid)
-  **Battery Hold** (plug-in hybrid)
  - Prioritizes maintaining the state of charge of the high-voltage battery, e.g. for subsequent journeys in inner cities/low-emission zones

- The hybrid system will select the appropriate drive type depending on the driving conditions
- **EL** **Electric** (plug-in hybrid)
  - Electric mode: driving without the combustion engine is possible up to approximately 77 mph (125 km/h).
  - Limits the maximum set speed for cruise control or Active Distance Assist DISTRONIC to the maximum speed possible in electric mode
  - Activates the combustion engine and changes to the **C** drive program via the first point of resistance of the haptic accelerator pedal
- **C** **Comfort**
  - Comfortable and economical driving
  - The hybrid system will select the appropriate drive type depending on the driving conditions (plug-in hybrid)
- **I\*** **Individual**

- Customised settings for drive, suspension, steering and ESP®
- **S** **Sport**
  - Sporty driving
  - Balance between stability and sportiness
  - Suitable only for good road conditions, a dry surface and a clear stretch of road
  - Drive with the combustion engine and reinforced boost effect (plug-in hybrid)
- **S\*** **Sport+**
  - Particularly sporty driving
  - Emphasizes the vehicle's own oversteer and understeer characteristics
  - Suitable only for good road conditions, a dry surface and a clear stretch of road
  - Drive with the combustion engine and reinforced boost effect (plug-in hybrid)
- **R** **Race**
  - Maximum sportiness

- Driving characteristics suited for the race-track with maximum or racetrack-optimize boost effect (plug-in hybrid)
- Particularly firm suspension tuning
- Sporty sound from the exhaust system



**i** The **R** drive program is available only for the **Mercedes-AMG C 63 S E Performance** model and for vehicles with the **AMG DYNAMIC PLUS package**.



The **R** drive program offers driving characteristics suited to the racetrack and must not be used on normal roads. The **R** drive program may be activated and used only on dedicated race circuits, not on public roads.

**Plug-in hybrid:** if the boost strategy is activated in the **R** drive program, the electric drive output will be metered in a way that is optimize for a racetrack. It will then be possible to use the maximum boost effect only deliberately via kickdown (→ page 28).

Mercedes-AMG recommends selecting drive program **C** when in city traffic or stop-and-go traffic.

Depending on the drive program selected, the following vehicle characteristics will change:



- Drive
  - Energy supply for the electric drive output (plug-in hybrid)
- AMG DYNAMICS
  - The four agility functions, Basic, Advanced, Pro and Master, will be selected automatically depending on the drive program.
  - The steering, shift timing point, all-wheel drive and stabilisation functions will be adapted to the selected drive program.
  - When ESP® is activated, the Pro agility function will be selected in drive program . The Master function will be selected automatically when ESP® is switched to SPORT  or is switched off .
- Real Performance Sound
- Sound of the drive system in the vehicle interior
- Suspension
- Steering

- Availability of Glide mode
  -  You can set the drive program characteristics using the multimedia system (→ page 20).
  -  You can adjust certain agility functions of AMG DYNAMICS using the AMG steering-wheel buttons.

### Select driving mode (Mercedes-AMG vehicles)

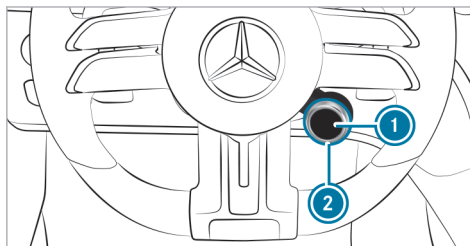



#### Selection with right-hand steering wheel button



- ▶ Turn the rotary-type switch . The selected driving mode will appear on the display button  and on the driver display.

-  Some driving modes may be hidden. The display of the driving modes and their order can be set in the multimedia system (→ page 20).

▶ **To select the driving mode  directly:** press display button .

-  **Plug-in hybrid:** Direct selection of the driving mode  by pushing the display button  is not possible. In a plug-in hybrid, you use the display button  to set the regeneration level (→ page 14).

### Selection via the central display (multimedia system)

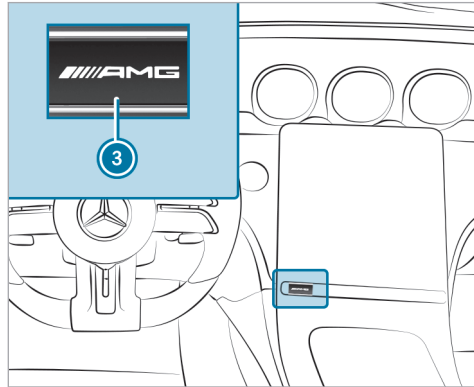

- ▶ Push the button ③ and select the driving mode via the central display (→ page 20).

### Configuring DYNAMIC SELECT in the multimedia system

Multimedia system:

- ▶ → ▶ Settings ▶ Vehicle
- ▶ ▶ DYNAMIC SELECT

#### Setting drive program I

- ▶ Select Individual.
- ▶ Select and set a category.

#### Switching the reset display on/off

- ▶ Activate or deactivate **Request at Start**.
- ① This function must be activated for each user profile separately. Only when this function is activated will the drive program and ECO start/stop setting for the previous journey be saved for the respective user profile.

**Function on:** the next time the vehicle is started a prompt appears asking whether the last active drive program should be restored. If the ECO start/stop function was deactivated, an additional prompt appears asking if the function should remain deactivated.

- ① The prompt appears only if the previously active settings deviate from the standard settings.

**Function off:** the next time the vehicle is started the drive program is set automatically. The ECO start/stop function is activated automatically.

#### Switching the reset display on/off (plug-in hybrid)

- ▶ Activate or deactivate **Request at Start**.
- ① This function must be activated for each user profile separately. The drive program for the respective user profile of the last driver is only stored if this function is activated.

**Function on:** the next time the vehicle is started a prompt appears asking whether the last active drive program should be restored.

- ① The prompt appears only if the previously active settings deviate from the standard settings.

## Setting AMG DYNAMIC SELECT in the MBUX multimedia system

Multimedia system:

- ➔ [Home] ➔ Settings ➔ Vehicle
- ➔ DYNAMIC SELECT

### Overview of the AMG DYNAMIC SELECT menu

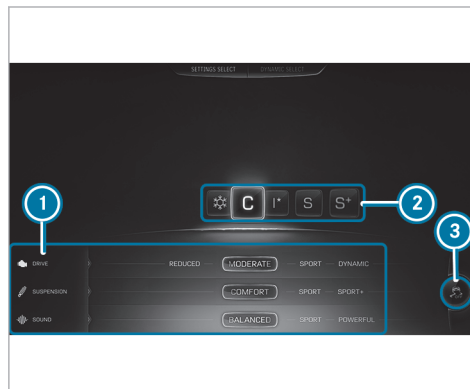

(Example of representation) Representation and arrangement of content equipment-dependent.

- ① AMG drive program settings
- ② Drive programs
- ③ ESP® (→ page 22)

① Depending on the equipment, the AMG **DYNAMIC SELECT** menu can also be called up using the AMG button in the center console.

▶ Select the appropriate drive program.

The settings of the drive programs can be adjusted individually.

▶ Select the desired tab on the left and make the relevant setting.

Setting options for the drive programs (equipment-dependent):

- AMG DYNAMICS:  
Basic/Advanced/Pro
- Suspension:  
Comfort/Sport/Sport+
- Sound:  
Balanced/Sport/Powerful
- Drive (can only be set in the [I+] drive program):  
Reduced/Moderate/Sport/Dynamic

## Automatic transmission

### Rocking the vehicle free

Rocking the vehicle back and forth may help to free the vehicle if it has become stuck in slush or snow.



To rock the vehicle free, move the DYNAMIC SELECT selector lever up and down past the pressure point in order to switch back and forth between transmission positions **D** and **R**.

- i** The maximum speed for shifting back and forth between **D** and **R** is about 6 mph (9 km/h).

### Manual shifting (Mercedes-AMG vehicles)

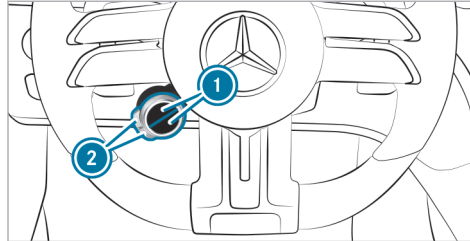
- i** You can also activate and deactivate manual shifting via the multimedia system (→ page 22).



- ▶ Press the upper or lower **1** display button repeatedly, until it displays the  symbol.
  - i** If the display button does not show the symbol, then it is hidden. How functions are displayed and the order in which they are displayed can be set in the multimedia system (→ page 13).
  - ▶ **Activate/deactivate:** Push the appropriate button **2**.
- The symbol indicates the currently selected transmission position:
-  **M** (red): manual shifting
  -  **D** (blue): Automatic

**Plug-in hybrid:** Automatic must be selected for electric driving. If you select manual shifting in driving mode **EL**, the driving mode switches to **C** and the combustion engine starts. If you are driving in driving mode **B** or **C** on electric power and select manual shifting, the combustion engine starts.

### Shifting up and down

**!** **NOTE** Damage to the engine due to shifting up too late

The automatic transmission does not shift up in manual mode even when the engine's limiting speed is reached.

The fuel supply is interrupted in order to prevent the engine from overrevving.

- ▶ Shift up before the engine speed reaches the red area in the tachometer.

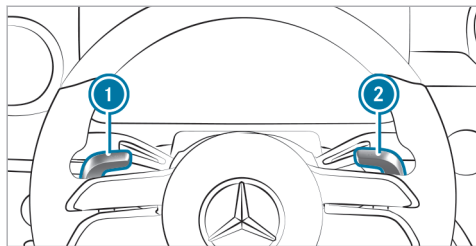

- ▶ **To shift up:** pull steering wheel paddle shifter ②.
- ▶ **To shift down:** pull steering wheel paddle shifter ①.

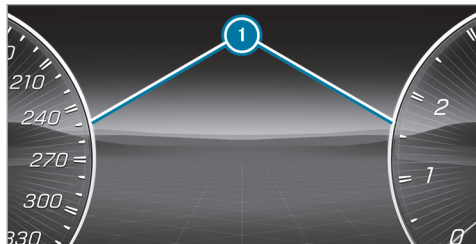

If the engine speed is too high or too low, you cannot change gears using the steering wheel paddle shifters. In this case, the segments ① on the driver display light up red.

### Permanently activating or deactivating manual gearshifting

Multimedia system:

→ » Settings » Vehicle » Driving

- ▶ Permanently switch the function on or off.

### Function of the gliding mode (Mercedes-AMG vehicles)

With an anticipatory driving style, gliding mode helps you to reduce fuel consumption.

When driving in gliding mode, the symbol appears on the driver display and the combustion engine is turned off. All of the vehicle functions remain active.

Gliding mode is activated if the following conditions are met:

- The ECO start/stop function is switched on.
- Drive program is selected with the drive setting "Moderate" or "Reduced".
- The speed is within a suitable range.
- The road's course is suitable, e.g. no steep uphill or downhill inclines or tight bends.
- The state of charge of the battery is sufficient.
- You are no longer depressing the accelerator or brake pedal.

Gliding mode is deactivated again if one of the conditions is no longer met.

### Driving and driving safety systems

#### Function of ESP® (Mercedes-AMG vehicles)

You can choose between the following modes of the Electronic Stability Program (ESP®):

- ESP® ON
- ESP® SPORT



- ESP® OFF

### Characteristics when ESP® is activated

ESP® monitors and improves driving stability and traction, particularly in the following situations:

- When you pull away on wet or slippery road surfaces.
- When you brake.
- When there is a strong crosswind and the vehicle's speed is between approximately 50 mph (80 km/h) and 125 mph (200 km/h)

ESP® can stabilize the vehicle by intervening in the following ways:

- Applying the brakes to one or more wheels
- Adapting the engine output according to the situation
- Adapting drive system output depending on the situation

ESP® will be activated every time the vehicle is started, regardless of whether ESP® SPORT or ESP® OFF was selected before the vehicle was switched off.

When the  warning lamp flashes, one or more wheels have reached their grip limit:



- Adapt your driving style to suit the prevailing road and weather conditions.
- Do not deactivate ESP® under any circumstances.
- Depress the accelerator pedal only as far as necessary when pulling away.

### Characteristics of ESP® SPORT

**⚠ WARNING** Risk of skidding if ESP® SPORT is used incorrectly

When you activate ESP® SPORT, there is an increased risk of skidding and having an accident.

▶ Activate ESP® SPORT only in the circumstances described below.

When ESP® SPORT is selected, the  and  warning lamps will light up continuously.

Select ESP® SPORT when the vehicle's own oversteer and understeer characteristics are desired, e.g. on cordoned-off roads.

Driving with ESP® SPORT or with ESP® deactivated requires an extremely skilled and experienced driver.

If ESP® SPORT is activated and one or more wheels start to spin, the  warning lamp will flash. ESP® then only stabilizes the vehicle to a limited degree.

ESP® SPORT also has the following characteristics:

- ESP® only improves driving stability to a limited degree.
- ETS/4ETS traction control is still active.
- The engine's torque is only restricted to a limited degree and the drive wheels can spin.

The power of the drive system is only restricted slightly according to the situation and the drive wheels can spin.

The spinning of the wheels results in a cutting action for better traction on loose surfaces.



- ESP® continues to provide assistance when the brakes are firmly applied.
- Crosswind Assist is no longer active.

### Characteristics when ESP® is deactivated

**⚠ WARNING** Risk of skidding if ESP® is deactivated

If you deactivate ESP®, ESP® cannot carry out vehicle stabilization.

- ▶ ESP® should only be deactivated in the following situations.

When ESP® is deactivated, the  and  warning lamps will light up continuously.

Deactivating ESP® has the following effects:

- Driving stability will no longer be improved.
  - The drive wheels could spin.
  - ETS/4ETS traction control will still be active.
  - Crosswind Assist will no longer be active.
- i** Even when ESP® is deactivated, you will still be assisted by ESP® when braking hard.

It may be best to activate ESP® SPORT or deactivate ESP® in the following situations:

- When using snow chains.
  - In deep snow.
  - On sand or gravel.
- i** Spinning the wheels will cause them to dig in to the surface, thereby enhancing traction.
- i** Activate ESP® as soon as the situations described above no longer apply. ESP® will otherwise not be able to stabilize the vehicle if the vehicle starts to skid or a wheel starts to spin.

If the  warning lamp lights up continuously, ESP® is not available due to a malfunction.

Observe the display messages and warning and indicator lamps that are shown.

- Warning and indicator lamps
- Display messages

### ETS/4ETS (Electronic Traction System)

ETS/4ETS traction control is part of ESP®.

ETS/4ETS can improve the vehicle's traction by intervening in the following ways:

- The brakes will be applied to the drive wheels individually if they spin.
- More drive torque will be transferred to the wheel or wheels with traction.

### Setting ESP® with the steering-wheel button

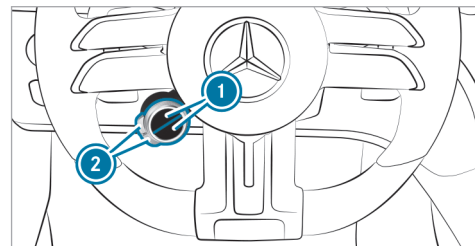

- i** You can also adjust ESP® via the multimedia system (→ page 25).



▶ **To set ESP®:** press upper or lower display button ① repeatedly, until it shows the  symbol.



① If the display button does not show the symbol, then it is hidden. How functions are displayed and the order in which they are displayed can be set in the multimedia system (→ page 13).



The color of the road in the  button symbol indicates the current setting:

-  (blue): ESP® ON
-  (yellow): ESP® SPORT
-  (red): ESP® OFF

▶ **To set ESP® SPORT:** briefly press button ② when ESP® is activated. The road in the  button symbol will light up yellow. The  and  warning lamps will appear on the driver's display.

▶ **To deactivate ESP®:** select ESP® SPORT and then press and hold button ②. The road in the  button symbol will light up red.

The  and  warning lamps will appear on the driver's display.

① When you deactivate ESP®  in the  drive program, AMG Dynamics will automatically switch to the **Master** level.

▶ **To activate ESP®:** briefly press button ② when ESP® SPORT is selected or ESP® is deactivated. The road in the  button symbol will light up blue. The  and  warning lamps will go out.

When the  symbol is shown with a red ! on the display button, ESP® is malfunctioning. Observe the information on warning lamps and display messages that are shown on the driver's display.



## Setting ESP® in the multimedia system





Multimedia system:



→  ► Settings ► Vehicle  
► DYNAMIC SELECT

① Depending on the equipment, the AMG DYNAMIC SELECT menu can also be called up using the AMG button in the center console.

ESP will always be activated when the vehicle is started. The road in the  button symbol lights up blue.

▶ **To set ESP SPORT:** when ESP is activated, briefly press  to change to the **Sport** program. The road in the  button symbol lights up yellow.

▶ **To deactivate ESP:** set the ESP SPORT program and press and hold  to deactivate ESP. The road in the  button symbol lights up red. The  and  warning lamps appear on the driver's display.

▶ **To activate ESP:** briefly press  in ESP SPORT or if ESP is deactivated. The road in the  button symbol lights up blue.

The  and  or  warning lamps go out.

❗ You can also set ESP via the steering-wheel buttons (→ page 24).

## RACE START

### Information on RACE START

RACE START enables optimal vehicle acceleration from a standstill. For this, a suitably high-grip road surface is required and the vehicle and tires must be in good condition.

- ❗ Use RACE START is only available after the vehicle has been broken in.
- ❗ RACE START must not be used in normal road operation. RACE START may be activated and used only on dedicated race circuits, not on public roads. Read the safety notes and information on ESP® (→ page 22).

**⚠ WARNING** Risk of skidding and having an accident from wheels spinning



If you use RACE START, depending on the ESP® mode selected, there is an increased risk of skidding and having an accident.

▶ Make sure that no persons or obstacles are in the close vicinity of your vehicle.

### Activating RACE START

#### Requirements

- The vehicle is switched on and the transmission and the engine are at normal operating temperature.
- The driver's door is closed.
- The front wheels are in the straight-ahead position.
- The vehicle is on level ground.
- The vehicle is stationary, the brake pedal is depressed (left foot) and the parking brake is released.
- The transmission is in position .

- One of the ,  or  drive programs is selected (→ page 16).

▶ Rapidly depress the accelerator pedal fully. The engine speed will increase.

❗ If the activation conditions are not fulfilled, RACE START cannot be used. The **RACE START Not Possible See Operator's Manual** message will appear on the driver display.

▶ The **RACE START Release Brake to Start** message will appear on the driver display.

❗ In this phase, you can adjust RACE START depending on the road conditions. You can vary the engine speed by pulling on one of the steering wheel paddle shifters. The segments on the driver display will flicker rapidly.

❗ If the brake pedal is not released after a short while, RACE START will be canceled. The **RACE START Canceled** message will appear on the driver display.

- ▶ Take your foot off the brake, but keep the accelerator pedal depressed. The vehicle will pull away at maximum acceleration. The **RACE START Active** message will appear on the driver display.

RACE START will be deactivated immediately if you release the accelerator pedal during RACE START or if any of the activation conditions is no longer fulfilled. The **RACE START Canceled** message will appear on the driver display.

- ⓘ After being used several times in short succession, RACE START will be unavailable until a certain distance has been driven.

## DRIFT MODE

### ■ Functions of DRIFT MODE

- ⓘ DRIFT MODE is only available for the **Mercedes-AMG C 63 S E Performance** model.

DRIFT MODE makes it possible to drive the vehicle intentionally in a controlled oversteer (drifting). For this, all activation conditions must be fulfilled (→ page 27).

- ⓘ Only a highly qualified and experienced driver should drive in DRIFT MODE. Read the safety notes and information on ESP® (→ page 22).

### ▲ **WARNING** Risk of skidding and having an accident from wheels spinning

When you use DRIFT MODE, ESP® is not available.

There is an increased risk of skidding and having an accident.

- ▶ Do not use DRIFT MODE on normal roads.
- ▶ DRIFT MODE may only be activated and used on closed race circuits, not on public roads.
- ▶ Make sure that no persons or obstacles are in the close vicinity of your vehicle.

When DRIFT MODE is active, the drive system of the vehicle only drives the rear axle. ESP® and 4MATIC+ are deactivated.

- ⓘ RACE START is only available after the vehicle has been broken in.

### ■ Activating and deactivating DRIFT MODE

#### Requirements

- ESP® is deactivated (→ page 24).
- Drive program  is selected (→ page 16).
- The doors, the hood and the trunk lid/tailgate are closed.
- The vehicle is started and the transmission and the engine are at normal operating temperature.
- The transmission is in manual mode – manual gearshifting is activated (→ page 21).

### Activating DRIFT MODE

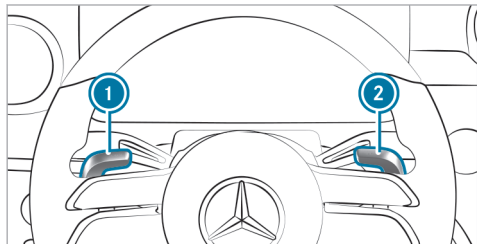

▶ Pull the steering wheel gearshift paddles ① and ② and hold them for half a second. If all activation conditions are fulfilled, the driver display will show a message reading **DRIFT MODE Confirm: Paddle UP Cancel: Paddle DOWN** and the **DRIFT** warning lamp will flash.

▶ **To cancel:** pull the steering wheel gearshift paddle ①. The driver's display will show the message **DRIFT MODE Canceled** and the **DRIFT** warning lamp will go out.

▶ **To confirm:** pull the steering wheel gearshift paddle ②. The driver display will show the message **DRIFT MODE Active** and the **DRIFT** warning lamp will light up.

### Deactivating DRIFT MODE

▶ Pull steering wheel gearshift paddles ① and ② and hold them for half a second. The **DRIFT MODE Active** message and the **DRIFT** warning lamp will go out.

DRIFT MODE will automatically be deactivated in the following situations:

- ESP® is activated.
  - Manual shifting is deactivated – the transmission is in position **D**.
  - The  drive program is switched off.
  - The vehicle is switched off.
  - Automatic switch-off is required by the vehicle.
- ① After drifting and before continuing your journey, check the wheels and tires for damage. In particular, check the tire tread depth and

tire contact surface over the entire width of the tires (see the vehicle Operator's Manual).

### Boost Strategy

#### Function of Boost Strategy

① Boost Strategy is only available for the **Mercedes-AMG C 63 S E Performance** model.

Boost Strategy is used to increase performance on a race track and can only be selected in drive program .

Boost Strategy is part of AMG TRACK PACE and can be activated either via the steering wheel button (→ page 29) or via the settings for Track Race (→ page 44).

You can set the energy flow and thus the energy supply of the electric drive power depending on the length of the race and its track characteristics.

For long races, activate Boost Strategy to use the maximum boost effect as needed exclusively via kickdown. Deactivate Boost Strategy for short races to always use the maximum electrical power.

## Activating/deactivating Boost Strategy with the steering-wheel button

### Requirements

- Drive program  is selected (→ page 16).
  - The state of charge of the high-voltage battery is sufficient.
- i** You can also activate or deactivate Boost Strategy via the Track Race settings (→ page 44).

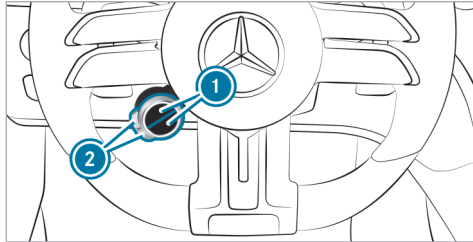



- ▶ Press upper or lower display button **1** repeatedly, until it displays the  symbol.

- i** If the display button does not show the symbol, then it is hidden. How functions are displayed and the order in which they are displayed can be set in the multimedia system (→ page 13).
- i** If the display is grayed out, the requirements for Boost Strategy are not met and it is not possible to activate the function.

- ▶ Press corresponding button **2**.

The symbol shows the current status:

-  (blue): Boost Strategy is activated
-  (yellow): Boost Strategy is deactivated

When Boost Strategy is activated, the driver's display also shows the  symbol in blue.

With an active boost process via kickdown, the **BOOST** message appears in the driver's display and the  symbols in the driver's display and on the display button light up yellow

## Notes on the driver display

**⚠ WARNING** Risk of accident if the driver's display fails

If the driver's display fails or malfunctions, you may not be aware of any functional limitations to safety-critical systems. This may affect the operating safety of the vehicle.

- ▶ Park the vehicle safely as soon as possible and notify a qualified specialist workshop.

The driver display shows the following basic information:

- Speed, engine speed and power meter level
- Range on map
- State of charge of the high-voltage battery
- Indicator and warning lamps

Additional functions available include the following:

- Various menus, e.g. **Classic**
- Status displays for the driving systems

- Display messages
- Information on electric range and distance **From Start** and **From Reset**



Trip computer (example)

- ① Proportion of driving done in electric mode (distance traveled under electric power per total distance traveled)

Information about range

- The actual range achieved may differ from the range displayed. Your previous driving style will be taken into account when the range is being calculated.

- Factors such as outside temperature or climate control settings have a direct influence on the achievable range.

Electric energy consumption

- The **From Start** and **From Reset** consumption figures take into account all active consumer equipment when it comes to the drive system's operational readiness.

Information on the proportion of driving done in electric mode

- When the proportion of driving done in electric mode is determined, only distances driven under the following conditions will be taken into account:
  - The combustion engine is switched off.
  - The Electric or Hybrid drive program is active.
  - The high-voltage battery is charged.



## Operating the driver display

**⚠ WARNING** Risk of distraction from information systems and communications equipment

If you operate information systems and communication devices integrated in the vehicle when driving, you could be distracted from the traffic situation. This could also cause you to lose control of the vehicle.

- ▶ Only operate this equipment when the traffic situation permits.
- ▶ If you cannot be sure of this, stop the vehicle whilst paying attention to road and traffic conditions and operate the equipment with the vehicle stationary.

Observe the legal requirements for the country in which you are currently driving when operating the driver display.

## Scrolling through the menu bar and calling up a menu

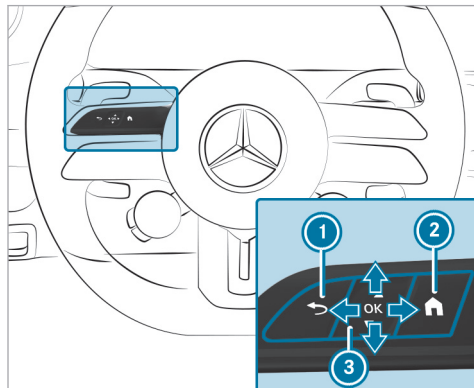

- ① Back button
- ② Main menu
- ③ Touch Control

You can manage the content of the driver display with the controls on the left of the steering wheel. You can navigate the content by swiping vertically

and horizontally with one finger on Touch Control ③. Press the Touch Control to confirm your selection.

- ① To operate Touch Control ③ in the most effective way, use the tip of your thumb if possible. You can also set the sensitivity of Touch Control on the central display.
- ▶ Briefly press main menu button ②.
- ▶ Select a menu by swiping to the left or right on Touch Control ③.
- ▶ **To confirm:** press Touch Control ③.

## Calling up or exiting the **Options** submenu

- ▶ **To call up:** press Touch Control ③.
- ▶ **To exit:** press back button ①.

## Browsing through display content or lists

- ▶ Swipe vertically or horizontally on Touch Control ③.
- ① On some menus, an index character will be displayed at the right edge of the center display content to indicate how the information has been sorted.

### Presetting displays

You can preset individually configured information of a menu and thus determine the standard display.

▶ Press Touch Control **3** until the bar is completely filled.

Answer the **Set Shortcut?** query as follows:

▶ Swipe to the left on Touch Control **3** and select **Yes**.

▶ **To confirm:** press Touch Control **3**.

▶ **To call up presets:** press back button **1** on the upper level of a menu.

**i** Pressing back button **1** on the standard display will open the previous menu.

### Resetting values

▶ **To call up the Options submenu:** press Touch Control **3**.

▶ **To select the function to be reset:** press Touch Control **3**.

▶ Select **Yes**.

▶ **To confirm:** press Touch Control **3**.

### Driver display menus

#### Classic or Understated menu (Mercedes-AMG vehicles)

Driver display:

➔ **Classic**

#### Selecting the center display content

The **Classic** menu shows the driver display separated into speedometer and tachometer. The area in between can be filled with various types of information.

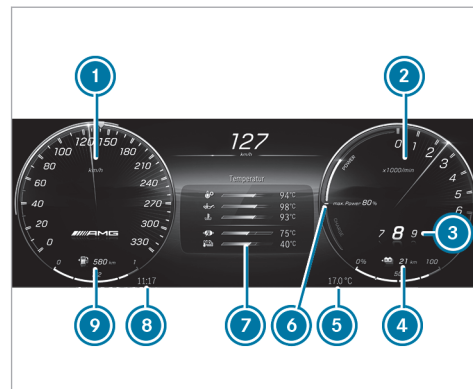

Illustration of plug-in hybrid vehicles (example)

- 1** Speedometer
- 2** Tachometer
- 3** Gear display
- 4** State of charge of the high-voltage battery
- 5** Outside temperature
- 6** Recuperation display and electric drive support display

- 7 Center display content (example: temperature)
  - 8 Time
  - 9 Fuel level and fuel filler flap location indicator
- ▶ Call up the **Classic** menu via the driver display menu bar.
- ▶ **To select display content:** swipe upwards or downwards on the left-hand Touch Control and select the display content.

The following information can be shown in the center display content:

- Trip and total distance
- Trip computer **From Start** and **From Reset**
- ECO display
- **Consumption**
- ATTENTION ASSIST
- **Audio**
- **Navigation**
- **Plug-in hybrid vehicles:** temperature (transmission oil, engine oil, coolant, high-voltage battery and high-voltage motor)

- **Vehicles with combustion engines:** temperature display (transmission oil, engine oil, coolant)
  - Set-up (drive, AMG DYNAMICS, suspension and sound)
  - Engine data (current power output and current torque)
- i Depending on the vehicle equipment, AMG-specific content regarding temperature, set-up and engine data will be displayed. You can set the display content either using the buttons on the multifunction steering wheel or via the MBUX multimedia system (→ page 20).

#### Changing the radio station or track on the station or track list

You can change radio stations or tracks on the station or track list in the center display content with audio information.

The following will be adjusted in the MBUX multimedia system:

- Configuring the station or track list
- Switching between media sources

- Setting the frequency band

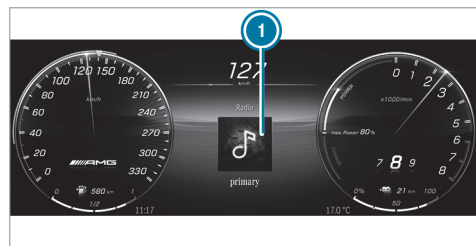

- i Radio stations in the center display content (example)

▶ **To change radio stations or tracks:** swipe left or right on the Touch Control and select a radio station or track on the station or track list.

- i If you do not select something immediately after opening the station or track list, the view will return to the radio station or track selected.

- ❗ The radio station or track displayed when the vehicle is restarted depends on the user profile used for the previous trip.

The following functions may be available on the **Options** submenu, for example:

- Navigation: selecting and adjusting zoom, route guidance and map settings
- Resetting the trip odometer
- Resetting the trip computer **From Start**
- Resetting the trip computer **From Reset**
- Resetting the ECO display values

### Changing color settings on the **Understated** menu

- ▶ Call up the **Understated** menu via the driver display menu bar.
- ▶ **To call up the color list:** press the Touch Control. The color list on the **Understated** menu will be displayed.

- ▶ **To select color settings:** swipe upwards or downwards on the left-hand Touch Control and change the color setting.

- ❗ If you do not select something immediately after opening the color list, the view will switch back to the default view for the **Understated** menu.

- ▶ **To exit the color list:** press the back button .

- ❗ Depending on the equipment, the selected color setting will also be adopted for the ambient lighting and the MBUX multimedia system. If you select the **Understated** menu on the driver display, the content in the MBUX multimedia system will also be made smaller.

### Service menu

Driver display:

 **Service**

The current status of the vehicle is shown on the **Service** menu.

- ▶ Press the main menu button  on the steering wheel.
- ▶ Swipe to the left or right on the Touch Control to select the **Service** menu on the menu bar of the driver display.
- ▶ **To call up the menu:** press the Touch Control.

The following display content is available on the **Service** menu (equipment-dependent):

- Information about how many messages are in the message memory
- **Tire Pressure:**
  - Checking the tire pressure with the tire pressure monitoring system
  - Restarting the tire pressure monitoring system
- **ASSYST PLUS:** calling up the service due date
- **Engine Oil Level:** checking the engine oil level
- **Plug-in hybrid vehicles:** temperature display (transmission oil, engine oil, coolant, high-voltage battery and high-voltage motor)

- **Vehicles with combustion engines:** temperature display (transmission oil, engine oil, coolant)

The following functions are available on the **Options** submenu:

- Tire pressure
- Message memory

## Supersport menu

Driver display:



### Selecting the center display content

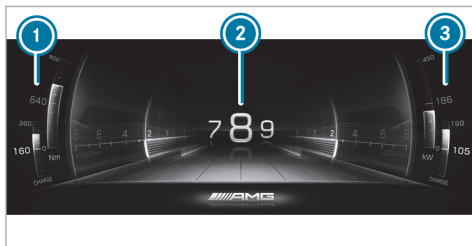

- 1 Current torque and recuperation display
- 2 Center display content (example: selected gear and electric drive support display)
- 3 Current power and recuperation display

▶ Press the main menu button  on the steering wheel.

▶ Swipe to the left or right on the Touch Control to call up the **Supersport** menu on the menu bar of the driver display.

▶ **To select display content:** swipe upwards or downwards on the Touch Control.

**i** Displays 1 and 3 vary depending on the center display content.

The center display content shows the following information:

- Transmission position display
- **Plug-in hybrid vehicles:** temperature display (transmission oil, engine oil, coolant, high-voltage battery and high-voltage motor)
- **Vehicles with combustion engines:** temperature display (transmission oil, engine oil, coolant)
- **Vehicles with combustion engines:** engine data
- Set-up (drive, AMG DYNAMICS, suspension and sound)
- G-force
- Trip and total distance

- Distance [From Start](#) and [From Reset](#)
- [Consumption](#)
- [Audio](#)
- [Navigation](#)

**i** Depending on the vehicle equipment, AMG-specific content regarding temperature, set-up and engine data will be displayed. You can configure the set-up display content either using the buttons on the multifunction steering wheel or via the MBUX multimedia system (→ page 20).

### Track Pace menu

Driver display:

↳ [TRACK PACE](#)

The Track Pace function is intended only for closed race tracks. Do not use this function on public roads, and adapt your driving style to your personal capabilities and the ambient conditions.

The following options will be displayed on the [TRACK PACE](#) menu:

- G-meter

- Race track selected
- Braking and acceleration procedure
- Gear currently selected



Indicators on the Track Pace menu (example)

- 1 G-meter
- 2 Center display content (example: gear display)
- 3 Telemetry display (example: selected race track)

▶ **To call up the menu:** press the Touch Control.

The content of the [TRACK PACE](#) menu will adapt to the selected settings on the central display:

- Gear display

- Braking points
- Acceleration
- Quarter-miles
- Race track selected on the central display
- Current race
- Record route

While the vehicle is in motion, the G-meter will show the forces that are exerted on the vehicle occupants both laterally and in the direction of travel. The maximum values will be shown in red in the coordinate system.

### Sport menu

Driver display:

↳ [Sport](#)

The [Sport](#) menu displays information about the engine data, the setup and the temperature of the vehicle.

▶ **To call up the menu:** swipe to the left or right on the Touch Control.

▶ **To confirm:** press Touch Control.

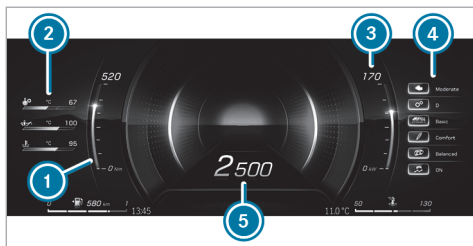

- ① Current torque
- ② Temperature (transmission oil temperature, engine oil temperature, coolant temperature)
- ③ Current power output
- ④ Set-up (drive position, transmission position, AMG DYNAMICS, suspension tuning, exhaust system, ESP®)
- ⑤ Engine speed
- i Depending on the equipment, AMG-specific content regarding temperature, setup and engine data will be displayed. You can set the setup display content using the buttons on the multifunction steering wheel or via the MBUX multimedia system (→ page 20). You

can also activate or deactivate ESP® using the steering wheel button or via the MBUX multimedia system .

### Function of the power meter

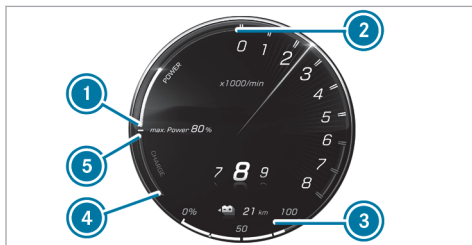

- ① Beginning of the electrical drive support display range
- ② End of the electrical drive support display range
- ③ Current state of charge of the high-voltage battery

- ④ Maximum recuperated energy
- ⑤ Start of the display range of recuperated energy
- i The Electric drive program is not available if the state of charge of the high-voltage battery falls below the minimum value of 25% ③. Electric mode is still possible when power output requests are low or when at a standstill.

The power meter has the following functions:

- In electric mode, the area ① - ② shows what percentage of the electrical drive is currently being used. The combustion engine is switched on at 100%. In boost mode, the electrical power assistance of the drive is displayed.
- The area ④ - ⑤ shows the recuperation and charging behaviour using the combustion engine.
- i Due to various system limits, the displayed value ④ may temporarily differ slightly from the actual value.

### Overview of status indicators on the driver display (Mercedes-AMG vehicles)

The status indicators for the driving and driving safety systems are shown in the ❶ and ❷ areas.

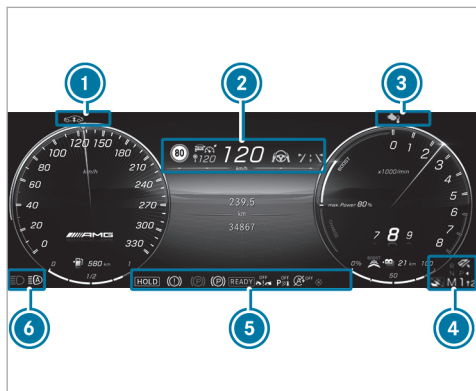



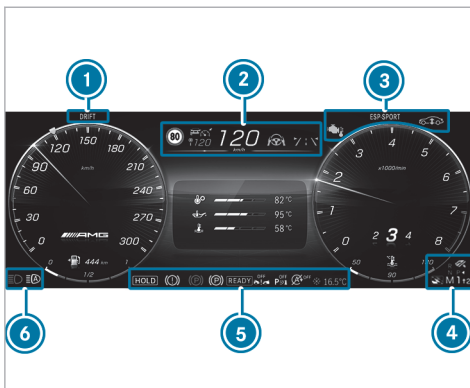











Vehicle with plug-in hybrid (example)











Vehicle with combustion engine (example)

❶ The number, position and presentation of the status indicators on the driver display depend on which systems are activated or deactivated.

Depending on the equipment, Mercedes-AMG vehicles have the following status displays:

-  Pedestrian detection (on assistant display only)
-  Active Parking Assist is available
-  Active Parking Assist has detected a parking space
-  Parking Assist PARKTRONIC deactivated
-  Cruise control
-  Active Distance Assist DISTRONIC
-  Specified distance for Active Distance Assist DISTRONIC
-  Active Brake Assist switched off
-  Active Brake Assist impaired or not functioning
-  Active Steering Assist
-  Active Lane Change Assist
-  Active Lane Keeping Assist
-  Active Blind Spot Assist (on assistant display only)
-  Plug-in hybrid operation activated



-  Haptic accelerator pedal
-  ECO start/stop function
-  HOLD function
-  Adaptive Highbeam Assist
-  Adaptive Highbeam Assist Plus
-  Active Stop-and-Go Assist
-  Slippery road surface warning
-  Engine operating temperature warning lamp (→ page 12)

**Vehicles with Traffic Sign Assist:** detected instructions and traffic signs

Important information from other driving systems may briefly appear in front of the displayed traffic signs.

## Operating Touch Control (MBUX multimedia system)

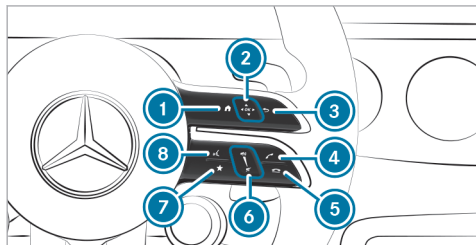

- ① Shows zero layer/home screen
- ② Touch Control
  - swipe in the direction of the arrow (navigate)
  - Press (confirm)
- ③ Returns to the previous display
- ④ Makes or accepts a call
- ⑤ Rejects or ends a call
- ⑥ Increases the volume of the current audio source: swipe upwards

Reduces the volume of the current audio source: swipe down

- Mutes the current audio source: press
- ⑦ Accesses favorites (press briefly) or adds favorites and themes (press and hold)
- ⑧ Starts the MBUX Voice Assistant
- ① To operate Touch Control ② in the most effective way, use the tip of your thumb if possible.

You can navigate through menus and lists via the touch-sensitive surface of Touch Control ② using a **single-finger swipe**, e.g.:

- ▶ **To enter a character:** select a character using the keyboard and press on Touch Control ②.
- ▶ **To select a menu option:** scroll in a list and press Touch Control ②.
- ▶ **To move the digital map:** swipe in any direction.
- ① Volume ⑥ can be adjusted using the control for the following groups:
  - Entertainment volume
  - Ringtone volume

- Call volume, for example phone call volume
- Voice output volume, for example MBUX Voice Assistant
- Volume of navigation announcements

If you are listening to a radio station, for example, and switch off the sound then all media sources will be muted. Traffic and navigation announcements can still be heard in this case. The MBUX Voice Assistant and telephony are also not affected.

## AMG TRACK PACE

### Function of AMG TRACK PACE

- ① This function is an on-demand feature and can be activated via Mercedes me after you purchase your vehicle. The Digital Operator's Manual contains further information on Mercedes me and on-demand features.

With AMG TRACK PACE, the driving characteristics on race tracks can be analyzed and optimized. You can drive previously saved race tracks

(e.g. the Hockenheimring), or record and save new tracks. The lap times set will be stored for every track. These can be analyzed and compared with other lap times to achieve the best possible race results. Additionally, acceleration and braking operations can be measured and stored.



**Note:** Use AMG TRACK PACE only on closed circuits away from public roads. Adapt your driving style to your personal skill level and environmental conditions. As the driver, you are solely responsible for driving your vehicle. Park your vehicle safely before operating the application.

## Setting Track Race



Multimedia system:

↳ TRACK PACE ▶ Track Race

### Recording a new track

- ▶ Select  **New Track** .
- ▶ Select  **Start Record**. at the desired starting point.  
The track recording starts at this point.

During track recording, sectors can be set to divide up the track.

- ▶  Select **Set Sector**.
- ▶ Select  **Stop Recording** to end track recording or cross the start line again.
- ▶ Confirm the prompt with **Yes**.
- ▶ Select the weather.
- ⓘ The temperature will be determined automatically.
- ▶ Enter a name.
- ▶ Press **OK** to confirm.  
The track will be saved under the name entered.

### Searching by track name

- ▶ Select  **Search** .
- ▶ Enter the track name.  
Tracks with the searched name are displayed.

### Measuring time on a saved track



- ▶  Select **All tracks**.
- ▶ Select the desired track.

- ▶ Select .
- ▶ Select **Start Time Recording** if you are already at the start line.

or

- ▶ Select **Navigate to** to navigate to the start line.

Timekeeping begins automatically when the starting line has been crossed.

- ⓘ When  is selected, the track display can be switched to AR. In addition, it is possible to switch to the telemetry display by selecting .
- ▶ Select  **Stop timekeeping** to end timekeeping.
- ▶ Confirm the prompt with **OK**.
- ▶ Select the weather.
- ▶ Select **Yes** to save the times set for this track.

### Showing readings during Track Race

The following readings can be shown:

- Tire temperature
- Miniature map

- Sector overview
- Engine data
- G-force display
- Lap overview

▶ Select  **Start Time Recording** .

▶ Select .

▶ Drag the desired display from the grid to the left or right edge of the central display. The readings will be shown during Track Race.

You can deactivate this by selecting  on the active display.

### Displaying the analysis

▶  Select **All tracks**.

An overview of all the driven tracks appears.

▶ Select a track.

▶ Select a session.

The following data is displayed:

- Lap and sector times
- average and maximum permissible speed
- driver

- Vehicle
- Date
- Weather

▶ Select **Add Recording** to use a different session as a reference value.

▶ Select  to return to the overview.

▶ Select **Diagram**.

▶ Set the desired parameters. The analysis is displayed.

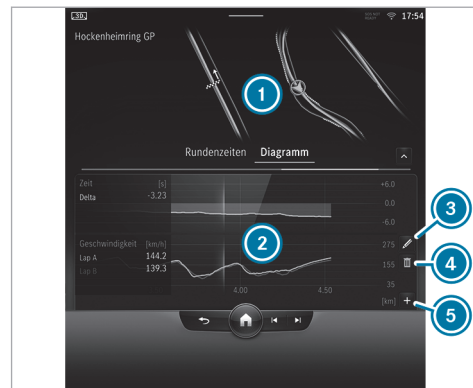

① Lap overview

② Parameter overview

③ Editing parameters

④ Deleting parameters

⑤ Adding new parameters



⑥ The following values can be set for the parameters, for example:

- Speed



- longitudinal/lateral acceleration
- Steering angle
- engine speed
- engine oil/tire temperature

Based on the analysis, you can check and optimize driving characteristics for any position on the track.

### Exporting tracks (USB)

- ▶ Select  **Tracks** .  
An overview of all stored tracks will appear.
- ▶ Select the desired track.
- ▶ Select options  for the desired track.
- ▶ Select **Export Track to...**  
The selected track can be exported to a USB storage device connected to the vehicle.

### Editing tracks and recordings

- ▶ Select  **Tracks** .
- ▶ Select the desired track.
- ▶ Select options  for the desired track.
- ▶ Select **Rename** or **Delete**.

or

- ▶ Select a track.
- ▶ Highlight the desired recording.
- ▶ Select  Options.
- ▶ Select **Export to...** or **Delete**.

### Setting Drag Race

Multimedia system:

↳ TRACK PACE ▶▶ Drag Race

### Measuring acceleration

- ▶ Select  **Drag race options**.
- ▶ Select **Acceleration**.
- ▶ Set a starting speed or select **Automatic**.  
Measurement will begin as soon as the specified starting speed has been reached.
- ▶ Set a target speed.  
Measurement will stop as soon as the specified target speed has been reached.
- ▶ Start off and begin the measurement.  
Measurement will begin when the vehicle accelerates.

You can stop measurement early by interrupting the acceleration procedure.

### Quarter-mile race

- ▶ Select  **Drag race options**.
- ▶ Select **Quarter Mile**.
- ▶ Set a target distance.  
Measurement will stop as soon as the specified target distance has been reached.
- ▶ Start off and begin the measurement.  
Measurement will begin when the vehicle accelerates. Timing will run until the target distance or a maximum of one mile has been traveled.

You can stop measurement early by interrupting the acceleration procedure.

### Measuring braking

- ▶  **Drag Race options**
- ▶ Select **Braking**.
- ▶ Set a starting speed or select **Automatic**.
- ▶ Start off and begin the measurement.

- ▶ Brake to a standstill. Measurement is incremental, in steps of 6 mph (10 km/h) to a standstill. If the braking procedure is started e.g. at a speed of 98 mph (157 km/h), measurement will start as soon as 93 mph (150 km/h) has been reached

### Storing and calling up measured values

If a measurement is completed or canceled, a prompt will appear asking whether the measurement should be saved.

- ▶ Confirm the prompt with **OK** to save.

### Calling up saved measurements

- ▶  Select **History**.
- ▶ Select **Acceleration**, **Quarter Mile** or **Braking**.
- ▶ Select a measurement. The desired measurement will be displayed in detail.

or

- ▶ Delete a measurement.

### Calling up the telemetry display

Multimedia system:

- ▶  **TRACK PACE** ▶▶ **Telemetry**

The telemetry display shows current vehicle data as a digital value and as a diagram. Up to four parameters can be selected to be shown on the display.

For example:

- Engine speed
  - Wheel angle
  - Speed
  - Steering angle
- ▶ Set the desired parameters.
  - ▶ Set the time. The set parameters will be evaluated for the selected time on the diagram.

### Configuring AMG TRACK PACE

#### Requirements

To connect a mobile device to the TRACK PACE app:

- the TRACK PACE app is installed on the mobile end device.
- the mobile end device is connected to the multimedia system via Wi-Fi.

Multimedia system:

- ▶  **TRACK PACE** ▶▶ 

### Connecting a mobile device via the TRACK PACE app

The TRACK PACE app makes it possible to record videos and to synchronize them with stored tracks.

- ▶ Select **TRACK PACE App**.
- ▶ Select **Authorize a New Device**.
- ▶ Start the TRACK PACE app on the device to be connected.
- ▶ Select **Continue** and confirm the authorization prompt. A four-digit code will be shown on the central display.
- ▶ Enter the code on your smartphone. The device is authorized.

### De-authorizing the mobile device

- ▶ Select **TRACK PACE App**.
- ▶ Select a device.
- ▶ Confirm the message prompt with Yes. The device is de-authorized.

### Setting the TRACK PACE display on the head-up display and driver's display

- ▶ Select **IC and HUD Contents**.
- ▶ Activate or deactivate the desired contents. The content on the head-up display and the driver's display will be adapted.
- ⓘ Further information about the head-up display .
- ⓘ Further information about the driver's display .

### Setting acoustic feedback

- ▶ Select **Acoustic Feedback**. A scale with values from 0 to 10 is shown.
- ▶ Select a setting.

### Displaying statistics

- ▶ Select **TRACK PACE Statistics**. Statistics on the current user profile will be displayed.
- The following data is displayed:
- Driving time
  - track driven
  - tracks recorded
  - Track Races recorded
  - laps recorded
  - Drag Races recorded
  - maximum design speed

### Activating the ambient light

If this function is active, the vehicle interior is lit red or green depending on Delta Time.

- ▶ Select **Ambient Light**.
- ▶ Activate or deactivate the function.

### Adjusting the dashcam

If the vehicle is equipped with a dashcam, it can be used in AMG TRACK PACE.

- ▶ Select **Dashcam**.
- ▶ Select **Track Race** or **Drag Race** and apply **Activate Recording**.
- ▶ You can set which overlay is to be used in the recorded video under **Video Overlay Content**.

### Activating boost strategy

This function is used to increase performance on a race track and is available only in the  drive program.

- ▶ Select **boost strategy**.
- ▶ Activate or deactivate the function.
- ⓘ The function is not available for all vehicle models.

### Notes on the care of tailpipes

**⚠ WARNING** Risk of burns from the tailpipe and tailpipe trims

The exhaust tailpipe and tailpipe trims can become very hot. If you come into contact with these parts of the vehicle, you could burn yourself.

- ▶ Always be particularly careful around the tailpipe and the tailpipe trims and supervise children especially closely in this area.
- ▶ Allow vehicle parts to cool down before touching them.

Observe the following notes in order to prevent damage to the vehicle:

- Clean the tailpipes with a cleaning agent recommended for Mercedes-Benz, especially in the winter and after washing the vehicle.
- Do not use acidic cleaning agents.



### Removing the warning triangle

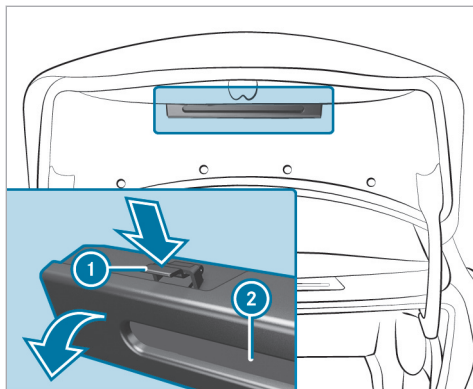

- ▶ Push warning triangle holder ① on both sides in the direction of the arrow and open it.
- ▶ Remove warning triangle ②.

The warning triangle is located in the trunk lid.

### Notes on starting assistance

Observe the information on starting assistance in the vehicle Operator's Manual.

If your vehicle has been started with starting assistance, it may not be possible to use the electric drive for approximately 30 minutes.

Starting assistance is not considered to be a normal operating condition.

Jumper cables and further information regarding starting assistance can be obtained at any qualified specialist workshop.

### Permissible towing methods (Mercedes-AMG E Performance)

#### ! NOTE Damage caused by towing

Towing can damage the hybrid system.

- ▶ Have the vehicle loaded and transported rather than towed.

### Changing a wheel

- ▶ Be sure to also observe the notes on changing a wheel in the Operator's Manual of your vehicle.

#### Vehicles with AMG ceramic high-performance composite braking system:

**!** **NOTE** Damage to the ceramic brake disc when changing a wheel

**Mercedes-AMG vehicles with ceramic brake discs:** during removal and repositioning of the wheel, the wheel rim can strike the ceramic-brake disc and damage it.

- ▶ Take particular care.
  - ▶ Ask another person for assistance or use a second alignment bolt.
- ▶ When changing the wheel, avoid exerting any force on the brake disks.  
This can lead to impaired comfort during braking.

## Operating fluids

### Fuel

#### Information on fuel quality for Mercedes-AMG vehicles

Observe the notes on operating fluids in the Operator's Manual for the vehicle.

**!** **NOTE** Damage caused by the wrong type of fuel

Even small amounts of the wrong type of fuel can result in damage to the fuel system, the engine and the emission control system.

▶ Refuel only with low-sulfur gasoline.

This fuel may contain up to 10 %- ethanol by volume. Your vehicle is suitable for use with E10- fuel.

Never refuel with any of the following fuels:

- Diesel
- Gasoline with more than 10 %- ethanol by volume, e.g. E15, E85, E100

- Gasoline with more than 3% methanol by volume-, e.g. M15, M30, M85, M100
- Gasoline with metallic additives

If you accidentally did fill up with the wrong fuel:

- ▶ Do not start the vehicle.
- ▶ Consult a qualified specialist workshop.

If the available fuel is not sufficiently low in sulfur, it may produce unpleasant odors.

Refuel only with premium-grade unleaded gasoline that has an octane number of at least 91 AKI/ 95 RON.

As a temporary measure, if the recommended fuel is not available, you may also use regular unleaded gasoline. When doing this, note the octane number on the information label inside the fuel filler flap (see the vehicle Operator's Manual). Filling up with regular unleaded gasoline may reduce engine output and increase fuel consumption.

Never refuel using gasoline with an even lower RON.

**!** **NOTE** Premature engine wear through unleaded regular gasoline

Impairment of the longevity and performance of the engine.

If unleaded premium grade gasoline is unavailable and you have to refuel using unleaded regular gasoline:

- ▶ Only fill the fuel tank to half full with unleaded regular gasoline and refill as soon as possible with unleaded premium grade gasoline.
- ▶ Do not drive at the maximum design speed.
- ▶ Avoid sudden acceleration and engine speeds over 3000 rpm.

Further information on fuel is available in the following locations:

- At a gas station
- At a qualified specialist workshop
- **USA only:** on the <https://www.mbusa.com>

### Tank content and fuel reserve (Mercedes-AMG vehicles)

Not for Mercedes-AMG E PERFORMANCE:

#### Total fuel tank capacity

Model	
Mercedes-AMG C 43 4MATIC	17.4 gal (66.0 liters)

#### Fuel tank reserve

Model	
Mercedes-AMG C 43 4MATIC	1.9 gal (7.0 liters)

#### Total fuel tank capacity (Mercedes-AMG E PERFORMANCE)

Model	
Mercedes-AMG C 63 S E PERFORMANCE	15.9 gal (60.0 liters)

#### Fuel tank reserve (Mercedes-AMG E PERFORMANCE)

Model	
Mercedes-AMG C 63 S E PERFORMANCE	2.6 gal (10.0 liters)

### Engine oil quality and filling capacity (Mercedes-AMG vehicles)

Not for Mercedes-AMG E Performance:

#### Engine oil specification

Model	MB-Freigabe or MB-Approval
Mercedes-AMG C 43 4MATIC	229.71*

Mercedes-AMG E Performance:

#### Engine oil specification (Mercedes-AMG E Performance)

Model	MB-Freigabe or MB-Approval
Mercedes-AMG C 63 S E Performance	229.71*

\* Recommended for the lowest possible fuel consumption (lowest SAE viscosity class in each case; observe possible restrictions of the approved SAE viscosity classes).

Use only engine oils of viscosity class SAE 0W-20.

Not for Mercedes-AMG E Performance:

#### Engine oil filling capacity

Model	Filling capacity
Mercedes-AMG C 43 4MATIC	6.3 US qt (6.0 liters)

Mercedes-AMG E Performance:

**Engine oil filling capacity**

Model	Filling capacity
Mercedes-AMG C 63 S E Performance	6.3 US qt (6.0 liters)

The specified filling capacity refers to an oil change with oil filter replacement.

**Coolant filling capacity (Mercedes-AMG vehicles)**

Not for Mercedes-AMG E Performance:

**Coolant**

Model	Filling capacity
Mercedes-AMG C 43 4MATIC	13.5 US qt (12.8 liters)

**Coolant (Mercedes-AMG E Performance)**

Model	Filling capacity
Mercedes-AMG C 63 S E Performance	14.8 US qt (14.0 liters)

**Filling quantity for refrigerant and PAG oil (Mercedes-AMG vehicles)**

Not for Mercedes-AMG E PERFORMANCE:

**Refrigerant filling capacity**

Model	
Mercedes-AMG C 43 4MATIC	21.2 ± 0.4 oz (600 ± 10 g)

**Filling quantity for PAG oil**

Model	
Mercedes-AMG C 43 4MATIC	2.8 ± 0.4 oz (80 ± 10 g)

**Refrigerant filling quantity (Mercedes-AMG E PERFORMANCE)**

Model	
Mercedes-AMG C 63 S E Performance	21.5 ± 0.4 oz (610 ± 10 g)

**PAG oil filling quantity (Mercedes-AMG E PERFORMANCE)**

Model	
Mercedes-AMG C 63 S E Performance	4.9 ± 0.4 oz (140 ± 10 g)

**Vehicle data**
**Vehicle dimensions (Mercedes-AMG vehicles)**

The heights specified may vary as a result of the following factors:

- Tires
- Load
- Condition of the suspension
- Special equipment

**Vehicle dimensions**

Mercedes-AMG C 43 4MATIC	Vehicle dimensions
Vehicle length	188.6 in (4791 mm)
Vehicle width including exterior mirrors	80.0 in (2033 mm)
Vehicle height	57.1 in (1450 mm)
Wheelbase	112.8 in (2865 mm)
Turning radius	39.3 ft (11.98 m)

**Vehicle dimensions (Mercedes-AMG E PERFORMANCE)**

Mercedes-AMG C 63 S E Performance	Vehicle dimensions
Vehicle length	190.6 in (4842 mm)
Vehicle width including exterior mirrors	80.0 in (2033 mm)
Vehicle height	57.4 in (1458 mm)

Mercedes-AMG C 63 S E Performance	Vehicle dimensions
Wheelbase	113.2 in (2875 mm)
Turning radius	39.7 ft (12.10 m)

**Weights and loads (Mercedes-AMG vehicles)**

Bear in mind that items of special equipment increase the curb weight and reduce the payload. Vehicle-specific weight information can be found on the vehicle identification plate.

**Maximum design speeds**

The following values only apply to vehicles with the AMG Driver's Package.

The maximum design speed may differ from the stated figures in practice. It depends on the operating conditions, the optional equipment and the size of the tires.

Missing values were not available at the time of going to press.

**Maximum design speed**

Model	
All models	

**High-voltage battery (Mercedes-AMG E PERFORMANCE)**

You can find information on the range in electric-only mode in the driver display .

Missing values were not available at the time of going to press.

**Energy content and charging times (Mercedes-AMG C 63 S E PERFORMANCE)**

Mercedes-AMG C 63 S E Performance	
Type	Lithium-ion
Maximum energy content	6.1 kW

**Mercedes-AMG C 63  
S E Performance**Range in all-electric  
modeCharging time - mode  
2  
with 1.4 kW charging  
power

- Mode 2 charging time applies to AC charging from 25 % to 100 % of the usable energy content.

The time taken to charge the battery depends on the state of charge of the battery, the ambient temperature and the charging power of the battery. The charging power, in turn, depends on the supply voltage, the current and the type of power supply.

The nominal voltage range for your vehicle can be found on the information label in the socket flap.

## Display messages

### Vehicle

Display messages	Possible causes/consequences and ► Solutions
Electronic Rear Axle Differential Lock Inoperative	<ul style="list-style-type: none"> <li>* The electronic locking differential has failed.               <ul style="list-style-type: none"> <li>► Consult a qualified specialist workshop.</li> </ul> </li> </ul>
Electronic Rear Axle Differential Lock Currently Unavailable	<ul style="list-style-type: none"> <li>* The electronic locking differential is overheated.               <ul style="list-style-type: none"> <li>► Let the electronic locking differential cool down by driving defensively.</li> </ul> </li> </ul>

### Driving and driving safety systems

Display messages	Possible causes/consequences and ► Solutions
RACE START Canceled	<ul style="list-style-type: none"> <li>* Possible causes:               <ul style="list-style-type: none"> <li>• you released the accelerator pedal during RACE START.</li> <li>• you depressed the brake pedal during RACE START.</li> </ul> </li> <li>► You can try RACE START again at the next start.</li> </ul>
RACE START Not Possible See Operator's Manual	<ul style="list-style-type: none"> <li>* Possible causes are:               <ul style="list-style-type: none"> <li>• The activation conditions have not been fulfilled (→ page 26).</li> </ul> </li> </ul>



Display messages	Possible causes/consequences and ► Solutions
<p>DRIFT MODE Currently Unavailable See Operator's Manual</p>	<p>* Possible causes:</p> <ul style="list-style-type: none"> <li>• The activation conditions have not been fulfilled (→ page 27).</li> </ul>
<p>AMG Ride Control Function Limited See Operator's Manual</p>	<p>* The system is outside the operating temperature range or the on-board electrical system voltage is too low. Once the cause of the problem is no longer present, the system will be available again.</p> <div style="border: 1px solid black; padding: 5px; margin: 5px 0;"> <p><b>!</b> <b>NOTE</b> The vehicle's suspension and damping behavior is restricted. The vehicle body may tilt heavily to the side during cornering.</p> <ul style="list-style-type: none"> <li>► Drive on carefully.</li> <li>► Reduce speed considerably before taking a bend.</li> <li>► Avoid sudden steering movements.</li> </ul> </div> <ul style="list-style-type: none"> <li>► Drive on carefully.</li> <li>► Reduce speed considerably before taking a bend.</li> <li>► Avoid sudden steering movements.</li> </ul>
<div style="border: 1px solid black; width: 40px; height: 40px; margin: 0 auto; text-align: center; line-height: 40px;">  </div> <p>Malfunction Do Not Exceed 50 mph</p>	<p>* </p> <ul style="list-style-type: none"> <li>► Do not drive at speeds greater than 50 mph (80 km/h).</li> <li>► Consult a qualified specialist workshop.</li> </ul>

## Warning and indicator lamps

## Engine

Warning/indicator lamp	Possible causes/consequences and ► Solutions
 <p data-bbox="144 467 408 515">Engine operating temperature warning lamp</p>	<p data-bbox="469 373 1641 422">*The blue warning lamp for engine operating temperature will remain lit until the engine operating temperature has been reached. The engine output and engine torque will remain reduced until then.</p> <p data-bbox="476 462 981 484">► Take this into consideration in your driving style.</p>

## Driving and driving safety systems

Warning/indicator lamp	Possible causes/consequences and ► Solutions
 <p data-bbox="144 756 408 779">DRIFT MODE warning lamp</p>	<p data-bbox="462 663 994 685">* DRIFT MODE is activated while the engine is running.</p> <div data-bbox="482 705 1646 743" style="background-color: #f0f0f0; padding: 5px;"> <p data-bbox="489 712 1240 739">▲ <b>WARNING</b> Risk of skidding and having an accident from wheels spinning</p> </div> <p data-bbox="495 754 1095 814">When you use DRIFT MODE, ESP® is not available. There is an increased risk of skidding and having an accident.</p> <p data-bbox="495 824 944 847">► Do not use DRIFT MODE on normal roads.</p>

Warning/indicator lamp	Possible causes/consequences and ► Solutions
	<ul style="list-style-type: none"> <li>► DRIFT MODE may only be activated and used on closed race circuits, not on public roads.</li> <li>► Make sure that no persons or obstacles are in the close vicinity of your vehicle.</li> </ul> <p>► Observe the notes on activating DRIFT MODE (→ page 27).</p>
	<p>* The yellow ESP<sup>®</sup> OFF warning lamps are lit while the vehicle is running. ESP<sup>®</sup> is deactivated. Other driving systems and driving safety systems may also be inoperative.</p> <p><b>▲ WARNING</b> Risk of skidding when driving with ESP<sup>®</sup> deactivated</p> <p>ESP<sup>®</sup> does not act to stabilize the vehicle. The availability of further driving safety systems is also limited.</p> <ul style="list-style-type: none"> <li>► Drive on carefully.</li> <li>► Deactivate ESP<sup>®</sup> only for as long as the situation requires.</li> </ul> <p>If ESP<sup>®</sup> cannot be activated, ESP<sup>®</sup> is malfunctioning.</p> <ul style="list-style-type: none"> <li>► Have ESP<sup>®</sup> checked immediately at a qualified specialist workshop.</li> </ul> <p>► Observe the notes on deactivating ESP<sup>®</sup> (→ page 22).</p>

Warning/indicator lamp	Possible causes/consequences and ► Solutions
 The image shows a rectangular indicator lamp icon. The top half features a car silhouette with a wavy line underneath it, and the word "OFF" in bold capital letters. The bottom half is a solid black rectangle with the words "ESP SPORT" in white capital letters.	<p>* ESP® SPORT is activated while the vehicle is running. When ESP® SPORT is activated, ESP® will stabilize the vehicle only to a limited extent.</p> <p><b>▲ WARNING</b> Risk of skidding if ESP® SPORT is used incorrectly</p> <p>When you activate ESP® SPORT, there is an increased risk of skidding and having an accident.</p> <ul style="list-style-type: none"><li>► Activate ESP® SPORT only in the circumstances described below.</li></ul> <p>► Observe the notes on activating ESP® SPORT(→ page 22).</p>



<b>A</b>		Oil temperature (driver's display).....	36	<b>Classic menu display content</b>	
<b>AMG ceramic high-performance composite brake system</b> .....	16	Steering wheel paddle shifters.....	21	Selecting.....	32
<b>AMG DYNAMIC SELECT</b>		<b>B</b>		<b>Climate control</b>	
Setting drive programs.....	20	<b>Battery (high-voltage on-board electrical system)</b> .....	52	Filling capacity for refrigerant and PAG oil.....	51
<b>AMG Real Performance Sound</b> .....	15	<b>Battery operation</b> .....	12	Pre-entry climate control when the vehicle is unlocked.....	10
<b>AMG steering wheel buttons</b>		<b>Boost pressure, current (driver's display)</b> .....	36	<b>Cockpit</b>	
Setting.....	13	<b>Boost Strategy</b>		Instrument panel.....	4
<b>AMG steering-wheel buttons</b>		Activating/deactivating (steering-wheel button).....	29	<b>Coolant</b>	
Function.....	13	Function.....	28	Capacity.....	51
<b>AMG TRACK PACE</b>		<b>Brakes</b>		<b>D</b>	
Boost Strategy.....	28	AMG ceramic high-performance composite brake system.....	16	<b>Dealership</b> .....	8
Configuring.....	44	<b>C</b>		<b>DIRECT SELECT lever</b>	
Drag Race.....	43	<b>Care</b>		Manual gearshifting.....	21
Function.....	40	Tailpipes.....	46	<b>Display (driver's display)</b>	
Telemetry display.....	44	<b>Charging</b>		Overview of displays.....	38
Track Race.....	41	Notes on charging the high-voltage battery.....	12	<b>Display messages</b>	
<b>Authorized Mercedes-Benz Service Center</b> .....	8			 <b>Malfunction Do Not Exceed 50 mph</b> .....	55
<b>Authorized workshop</b> .....	8				
<b>Automatic transmission</b>					
Drive programs.....	16				
DYNAMIC SELECT button.....	16				
Manual gear shifting.....	21				

AMG Ride Control Function Limited			
See Operator's Manual.....	55		
DRIFT MODE Currently Unavailable			
See Operator's Manual.....	55		
Electronic Rear Axle Differential Lock			
Currently Unavailable.....	54		
Electronic Rear Axle Differential			
Lock Inoperative.....	54		
RACE START Canceled.....	54		
RACE START Not Possible See Operator's Manual.....	54		
Drag Race.....	43		
DRIFT MODE			
Activating.....	27		
Activation conditions.....	27		
Deactivating.....	27		
Function.....	27		
Drive program display.....	18		
Drive programs			
AMG DYNAMIC SELECT.....	20		
Selecting.....	18		
Driver display, Instrument cluster			
Function/notes.....	30		
Service menu.....	34		
Track Pace menu.....	36		
Driver's display			
Classic menu.....	32		
Operating.....	31		
Status displays.....	38		
Supersport menu.....	35		
Understated menu.....	32		
Driving safety system			
ESP® (Electronic Stability Program).....	22		
Driving tips			
AMG ceramic high-performance composite brake system.....	16		
DYNAMIC SELECT			
Configuring drive program I.....	19		
Drive program display.....	18		
Drive programs.....	16		
Function.....	16		
Selecting the drive program.....	18		
<b>E</b>			
E10.....	49		
E25.....	49		
ECO start/stop button			
Automatic engine start/stop.....	14		
ECO start/stop function			
Switching off/on.....	14		
Electric drive.....	12		
Electronic Stability Program.....	22		
Engine oil			
Capacity.....	50		
MB-Freigabe or MB-Approval.....	50		
Quality.....	50		
Temperature (driver's display).....	36		
Engine oil temperature (driver's display).....	36		
Engine operating temperature			
Warning lamp.....	12		
Engine output.....	12		
Engine output, current (driver's display).....	36		
Engine sound.....	15		
Engine torque.....	12		
Environmentally friendly driving.....	6		
ESP®			
Activating/deactivating.....	25		

ESP® SPORT.....	22				
Function.....	22				
Setting (steering-wheel button).....	24				
<b>F</b>					
<b>Fuel</b>					
E10.....	49				
E25.....	49				
Gasoline.....	49				
Gasoline quality.....	49				
Reserve.....	50				
Sulfur content.....	49				
Tank capacity.....	50				
<b>Fuel reserve</b> .....	50				
<b>G</b>					
<b>G-meter, Accelerometer</b> .....	36				
<b>Gasoline</b> .....	49				
<b>Gearshift</b>					
Manual.....	21				
<b>Glide mode</b> .....	22				
		<b>H</b>			
		<b>High-voltage battery</b>			
		Charging duration.....	52		
		General notes on charging.....	12		
		Range.....	52		
		Type.....	52		
		<b>I</b>			
		<b>Individual drive program</b>			
		Configuring.....	19		
		<b>Installing</b>			
		Tires/wheels.....	48		
		<b>Instrument panel</b>			
		Cockpit.....	4		
		<b>M</b>			
		<b>Malfunction</b>			
		Restraint system.....	9		
		<b>Manual gearshifting</b>			
		Activating/deactivating.....	22		
		<b>Maximum speeds</b> .....	52		
		<b>MBUX multimedia system</b>			
		Drive programs.....	19		
				<b>Medical aids</b> .....	8
				<b>Menus (driver display)</b>	
				Service.....	34
				Track Pace.....	36
				<b>Menus (driver's display)</b>	
				Classic menu.....	32
				Sport.....	36
				Supersport.....	35
				Understated menu.....	32
				<b>Mirror heater</b> .....	10
		<b>O</b>			
				<b>Operating fluids</b>	
				Gasoline.....	49
				<b>Operating safety</b> .....	6
				<b>Operator's manual</b> .....	6
		<b>P</b>			
				<b>Paddle shifters</b>	
				Steering wheel paddle shifters.....	21
				<b>Permitted towing methods</b>	
				Overview.....	47

<b>Plug-in hybrid operation</b>			
Notes on plug-in hybrid operation.....	12		
Sets recuperation.....	14		
<b>Power meter, Output</b>			
Function/note.....	37		
<b>Pre-entry climate control</b>			
When vehicle is unlocked.....	10		
<b>Pre-heating</b> .....	10		
<b>Programs</b> .....	16		
<b>Protection of the environment</b>			
Driving style.....	6		
<b>Q</b>			
<b>Qualified specialist workshop</b> .....	8		
<b>R</b>			
<b>RACE START</b>			
Activating.....	26		
Activation conditions.....	26		
Information.....	26		
<b>Racetrack mode</b>			
AMG ceramic high-performance composite brake system.....	16		
		AMG steering-wheel buttons.....	13
		<b>Recuperation</b>	
		Setting.....	14
		<b>Reserve</b>	
		Fuel.....	50
		<b>Restraint system</b>	
		Malfunction.....	9
		<b>Rocking free</b> .....	21
		<b>S</b>	
		<b>Seat belts</b>	
		Reduced protection.....	9
		<b>Selecting a gear</b> .....	21
		<b>Selecting a sound characteristic (steering-wheel button)</b> .....	15
		<b>Service</b>	
		Menu (driver display).....	34
		<b>Service center</b> .....	8
		<b>Shifting</b>	
		Automatic transmission.....	21
		Manual.....	21
		Steering wheel paddle shifters.....	21
		<b>Sound</b>	
		AMG Real Performance Sound.....	15
		<b>Specialist workshop</b> .....	8
		<b>Starting assistance</b> .....	47
		<b>Steering wheel paddle shifters</b> .....	21
		<b>Stop and go</b>	
		ECO start/stop function.....	14
		<b>Sulfur content</b> .....	49
		<b>Supersport menu display content</b>	
		Selecting.....	35
		<b>T</b>	
		<b>Tailpipes</b>	
		Care.....	46
		<b>Tank capacity</b>	
		Fuel.....	50
		Reserve.....	50
		<b>Technical data</b>	
		High-voltage battery.....	52
		Maximum speeds.....	52
		Vehicle dimensions.....	51
		<b>Telemetry display</b> .....	44



- Tires**
    - Installing..... 48
  - Torque (driver's display)**..... 36
  - Touch Control**
    - Driver's display..... 31
    - MBUX..... 40
  - Towing**
    - Towing methods..... 47
  - Towing methods**
    - Overview..... 47
  - Track Pace**
    - Menu (driver display)..... 36
  - Track Race**..... 41
- U**
- Understated menu display content**
    - Selecting..... 32
- V**
- Vehicle**
    - Equipment..... 6
    - Medical aids..... 8
    - Rocking free..... 21
    - Towing away..... 47
  - Vehicle data**
    - Maximum speeds..... 52
    - Turning circle..... 51
    - Vehicle height..... 51
    - Vehicle length..... 51
    - Vehicle width..... 51
    - Weights..... 52
    - Wheelbase..... 51
  - Vehicle dimensions**..... 51
  - Vehicle equipment**..... 6
- W**
- Warning triangle**..... 47
  - Warning/indicator lamp**
    -  DRIFT MODE warning lamp..... 56
    -  Engine operating temperature warning lamp..... 56
  - Wheel change**
    - Installing a new wheel..... 48
  - Wheels**
    - Installing..... 48
  - Workshop**..... 8

